



EQUIPMENT SHEET

HDW1
600 TONS SALVAGE DEBRIS GRAB



HISTORY AND LIFETIME EXTENSION

The SMIT debris grab 'HDW 1' has been put into action successfully for many wreck removal projects.

It is one of the biggest salvage debris grabs in its class with a net grabbing capacity of 600 tons.

Complete lifetime extension in 2007

Mechanical wire rope system converted into an electrical-hydraulic actuation of the grab which increases the grabbing force.

The electrical-hydraulic system significantly improved in 2015 which made the system less complex and more robust.

TECHNICAL DESCRIPTION

Grab In operation it is connected to the blocks of a sheerlegs crane to control the hoisting height/depth of the grab. The grab itself is equipped with three vertical mounted hydraulic cylinders for opening and closing of the grab. The cylinders are actuated by means of a subsea power pack mounted within steel construction of the grab.

Electrical power supply The electrical power supply to the grab is provided via an umbilical winch from the main deck of the sheerlegs. The grab is operated via a control box which can be located on the bridge of the sheerlegs. This in combination with a sonar survey system leads to accurate positioning resulting in high production.

TECHNICAL SPECIFICATION

Own weight in air	250 t
Grabbing capacity	600 t
Hoisting speed	60 - 90 m/min depending on sheerlegs
Opening/Closing sequence	15 minutes/sequence
Maximum grabbing force	300 to 900 t
Control System	Remote computer controlled controlled
Monitoring Systems	Sensors: pressure, temperature, inclination, open/close. Provided with cameras and lights.

REFERENCE PROJECTS

- Tricolor [Northsea Channel, France]
- Westerschelde projects [38 wrecks]
- Hyundai 105 (Singapore)
- Baltic Ace (North Sea, The Netherlands)



HDW1
600 TONS SALVAGE DEBRIS GRAB

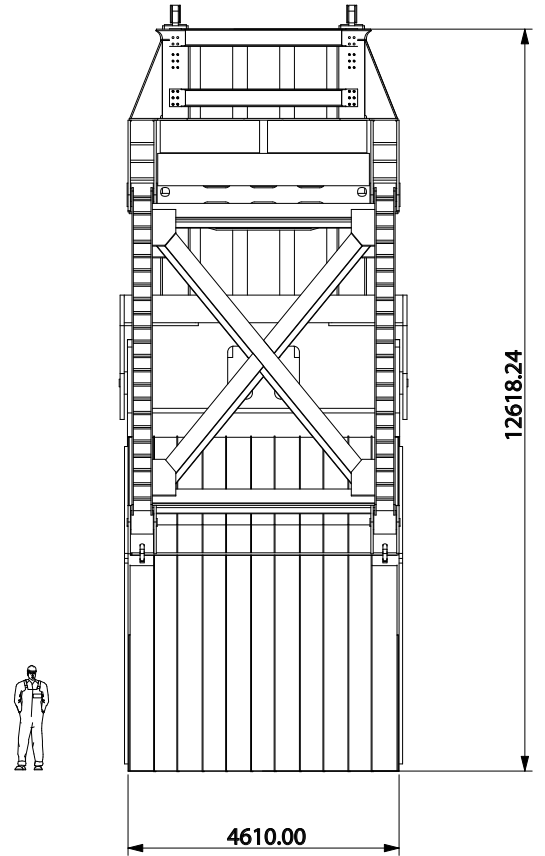
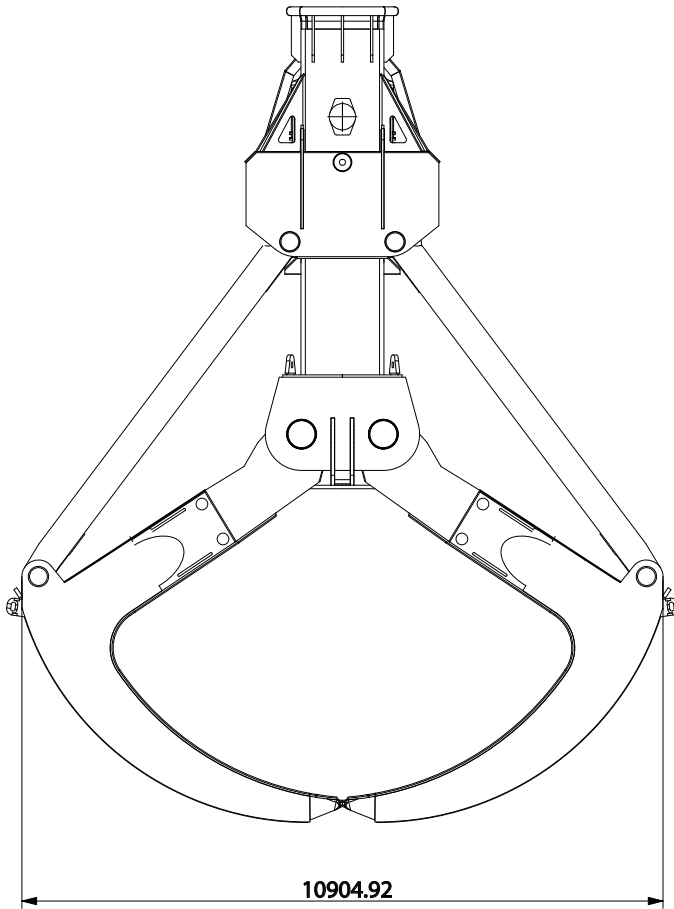

The information contained in this data sheet is for guidance purposes only and may be subject to changes. © Boskalis. All rights reserved.

11 - 2015